

# COMPONENT LISTING

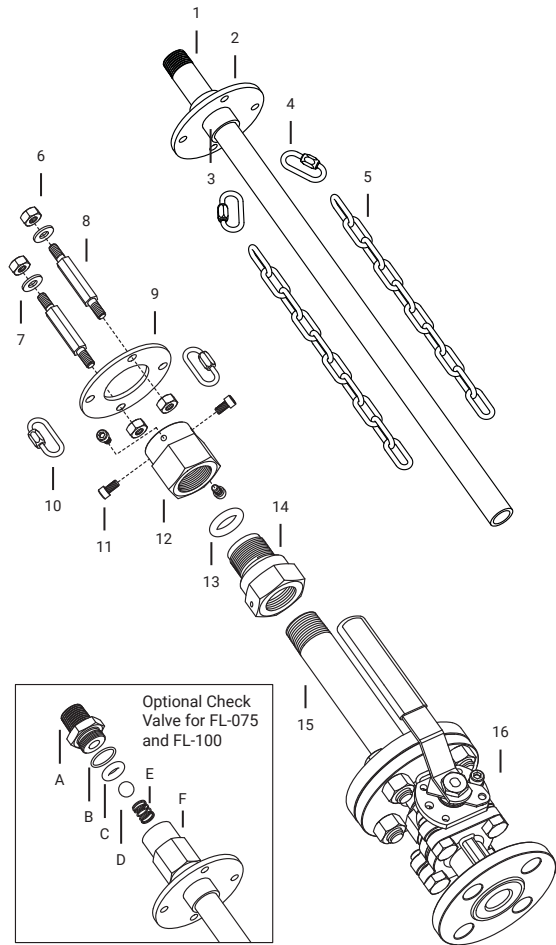

ID	Name
<b>Solution Tube Assembly</b>	
1	Solution Tube (Inlet Thread)
2	Upper Chain Plate
3	Collar
4	Threaded Connector (x2)
5	Limit Chain (x2)
<b>Ball Valve Assembly</b>	
6	Lock Nut (x4)
7	Washer (x2)
8	Connector Bolt (x2)
9	Lower Chain Plate
10	Threaded Connector (x2)
11	Restraint Screw (x4)

ID	Name
12	Packing Nut
13	Compression O-ring
14	Solution Tube Adapter
15	Guide Pipe Assembly
16	Flanged Ball Valve
<b>Optional Integrated Check Valve (FL-075 and FL-100)</b>	
A	Upper Check Valve Housing
B	Check Valve Seal
C	Check Valve Seat
D	Check Ball
E	Spring
F	Lower Check Valve Housing

## WARRANTY

All merchandise is warranted to be free from defects in material and factory workmanship. We will provide free of charge new products in equal quantities for any that prove defective within one year from date of shipment from our factory. Manufacturer shall not be liable for any loss, damage, or injury, direct or consequential, arising out of the use of or the inability to use the product. Before using, user shall determine the suitability of the product for its intended use and user assumes all risk and liability whatever in connection therewith. No claims for labor or consequential damage will be allowed. The foregoing may not be changed except by agreement signed by an officer of the manufacturer.



SAF-T-FLO Chemical Injection

Please contact our Asia Pacific distributor:



**H2O Rx**

ABN: 97 217 924 685

Phone: 0409 784 236

Email: info@h2orx.com.au

[www.h2orx.com.au](http://www.h2orx.com.au)

PO Box 748, Lane Cove NSW 1595



## INSTALLATION AND OPERATION MANUAL

Flanged Heavy Service Retractable Injection  
Quill  
FL Series

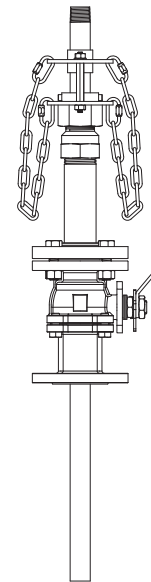

# INSTALLATION

## BEFORE INSTALLING

- Quills are shipped in their operating configuration. Installation may require that the solution tube be removed.
- Hot tapping is not recommended. If planning on hot tapping, please refer to the technical references available at [www.saftflo.com](http://www.saftflo.com) or contact SAF-T-FLO technical assistance.
- It is recommended that you do not disassemble the packing gland for installation of the quill. The threads of the gland will not be protected and may become damaged. Such damage is not covered under warranty.
- If the quill does not include the optional check valve, precaution must be taken to ensure that there is some means of isolation in place prior to exposing the solution tube to the process pressure.

## INSTALLING WITH SOLUTION TUBE INSERTED

1. Apply suitable thread sealant to the process connection thread.
2. Install the quill onto the process line by threading the main connection valve to the tap on the process line.
3. Connect the chemical feed line to the inlet of the quill.

## INSTALLING WITH SOLUTION TUBE REMOVED

1. With the valve in the closed position. Apply suitable thread sealant to the process connection thread.
2. Install the main connection valve onto the tap of the process line.
3. Insert the solution tube following the solution tube insertion instructions in this manual.
4. Connect the chemical feed to the inlet of the quill.

## AFTER INSTALLING / PRIOR TO OPERATING

1. Inspect the restraint system to ensure that it is properly in place and ready for operation. Check to verify that:
  - a. Restraint and limit chains are connected to the packing nut using the supplied screws and washers.
  - b. Restraint chain is hooked off onto the restraint hook and both chain and hook are fully extended.
  - c. Limit chain is connected the threaded connector and the jaw of the connector is closed.
2. Prior to exposing solution tube to the process pressure make sure there is a means of isolation in place to prevent process pressure from coming back up through the solution tube.
3. Ensure all connections have been made prior to pressurizing.

# OPERATION

## PRECAUTIONS

- Process pressure should be reduced as much as possible prior to inserting or retracting the solution tube.
- Inspect restraint hardware to ensure it is in proper condition.
- Do not stand directly in line with the quill when operating.
- Take all necessary precautions to protect against possible chemical exposure when working with the quill.
- Do not use a wrench when tightening the packing nut. Hand tighten only.

## INSERTING THE SOLUTION TUBE

1. Inspect the restraint hardware to ensure that it is suitable for use.
2. Insert the solution tube into the valve assembly until the tip contacts the ball of the closed isolation valve.
3. Connect the limit chains to the threaded connectors. For each chain, one end should attach to a threaded connector on the lower chain plate and the other end should attach to a threaded connector on the upper chain plate. Close the jaws of the threaded connectors. Chains should be extended with no kinks and minimal slack.
4. Hand tighten the packing nut until resistance is felt.
5. For models not equipped with an optional check valve, make sure there is a point of isolation in place and active at the inlet of the quill before proceeding.
6. Slowly open the valve. Allow the limit chains to take up the pressure. Tighten the packing nut to seal off any leaks.
7. Once the valve is fully open, slide the solution tube through the valve assembly until the threaded ends of the connector bolts pass through the holes of the upper chain plate. Use the lock nuts and washers to lock off the restraint system.
8. Connect the chemical feed to the quill.

## RETRACTING THE SOLUTION TUBE

1. Shutdown and isolate the chemical feed from the quill. Detach feed piping as needed to ensure the quill can retract unobstructed.
2. Maintain a firm grasp on the upper chain plate of the solution tube and remove the upper locknuts.
3. Slowly back out the solution tube until the limit chains are fully extended.
4. Isolate from the process pressure by closing the isolation valve.
5. Slowly back off the packing nut to bleed off residual pressure.
6. With the isolation valve closed and the residual pressure bled off, undo the limit chains from the threaded connectors on the upper chain plate.
7. Finish by sliding the quill completely out of the valve assembly.

# MAINTENANCE

## VISUAL INSPECTION

Periodic visual inspections should be done to examine the overall integrity of the quill and to verify that no leaks (chemical or process side) have developed.

## SOLUTION TUBE MAINTENANCE

Solution tubes may clog due to deposit formation. The rate and severity will depend on the chemistry of the application. After the quill is put into operation it should be periodically retracted to determine the rate at which the deposit formation is occurring. Maintenance cycles can then be based on observations.

Deposits can typically be removed by soaking the tube in warm water and then brushing the deposits off. In other cases a weak acid solution may be utilized.

## CHECK VALVE MAINTENANCE

Deposits can also impact the operation of the spring loaded check valve. With the tube removed, the internals of the check valve can be accessed by unthreading the upper housing from the lower check valve body.

Ensure that no deposits are impeding the operation of the ball and spring. Inspect seals to ensure they are in good condition. Check Valve Repair Kits, which include the spring, ball, and o-rings, are available.

## REPLACEMENT PARTS

The following sub-assemblies and kits are available for replacement:

- Solution Tube Assembly
- Main Connection Assembly
- Check Valve Repair Kit (FL-075 and FL-100 with optional check valves)
- Check Valves (FL-125 and larger with optional check valve)

## NEED ASSISTANCE?

### CUSTOMER SERVICE

800-957-2383

M-F (7am - 4pm Pacific)

### INSTRUCTIONAL VIDEOS

<https://saftflo.com/videos>