

# COMPONENT LISTING

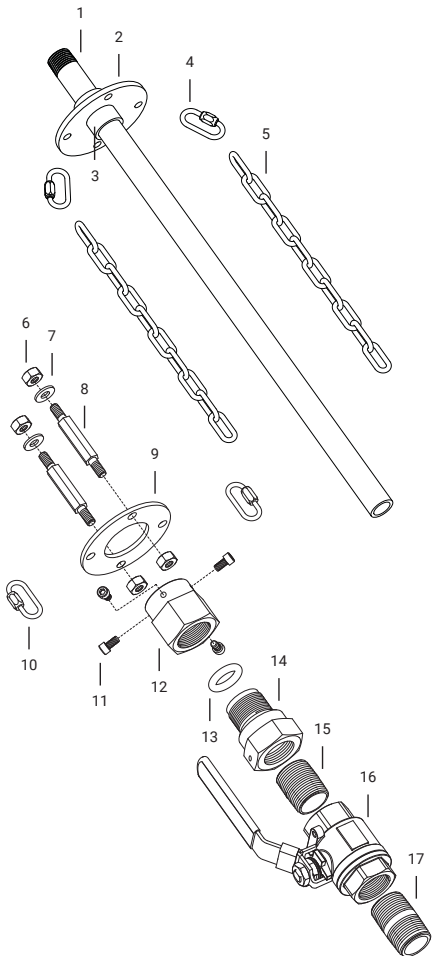

ID	Name	ID	Name
<b>Solution Tube Assembly</b>			
1	Solution Tube (Inlet Thread)	9	Lower Chain Plate
2	Upper Chain Plate	10	Threaded Connector (x2)
3	Collar	11	Restraint Screw (x4)
4	Threaded Connector (x2)	12	Packing Nut
5	Limit Chain (x2)	13	Compression O-ring
<b>Ball Valve Assembly</b>			
6	Lock Nut (x4)	14	Solution Tube Adapter
7	Washer (x2)	15	Upper Nipple
8	Connector Bolt (x2)	16	Ball Valve
		17	Lower Nipple (Process Connection Thread)

## WARRANTY

All merchandise is warranted to be free from defects in material and factory workmanship. We will provide free of charge new products in equal quantities for any that prove defective within one year from date of shipment from our factory. Manufacturer shall not be liable for any loss, damage, or injury, direct or consequential, arising out of the use of or the inability to use the product. Before using, user shall determine the suitability of the product for its intended use and user assumes all risk and liability whatever in connection therewith. No claims for labor or consequential damage will be allowed. The foregoing may not be changed except by agreement signed by an officer of the manufacturer.



SAF-T-FLO Chemical Injection

Please contact our Asia Pacific distributor:



**H2O Rx**

ABN: 97 217 924 685

Phone: 0409 784 236

Email: info@h2orx.com.au

[www.h2orx.com.au](http://www.h2orx.com.au)

PO Box 748, Lane Cove NSW 1595



## INSTALLATION AND OPERATION MANUAL

**Heavy Service (HS) Series Retractable Injection Quills**  
 HS-075, HS-100, HS-125, HS-150, HS-200, HS-250, HS-300

**High Corrosion Resistant (HC) Series Retractable Injection Quills**  
 HC-150, HC-150, HC-200, HS-250, HS-300

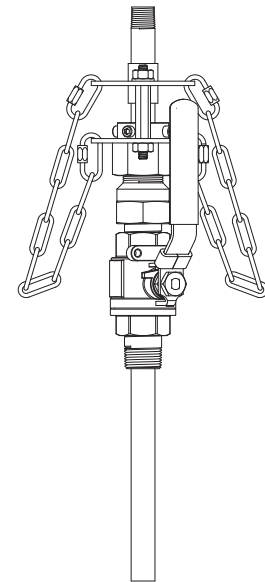

# INSTALLATION

## BEFORE INSTALLING

- Quills are shipped in their operating configuration. Installation may require that the solution tube be removed.
- Hot tapping is not recommended. If planning on hot tapping, please refer to the technical references available at [www.saftflo.com](http://www.saftflo.com) or contact SAF-T-FLO technical assistance.
- It is recommended that you do not disassemble the packing gland for installation of the quill. The threads of the gland will not be protected and may become damaged. Any such damage is not covered under warranty.
- If the quill does not include the optional check valve, precaution must be taken to ensure that there is some means of isolation in place prior to exposing the solution tube to the process pressure.

## INSTALLING WITH SOLUTION TUBE INSERTED

1. Apply suitable thread sealant to the process connection thread.
2. Install the quill onto the process line by threading the main connection valve to the tap on the process line.
3. Connect the chemical feed line to the inlet of the quill.

## INSTALLING WITH SOLUTION TUBE REMOVED

1. With the valve in the closed position, apply suitable thread sealant to the process connection thread.
2. Install the main connection valve onto the tap of the process line.
3. Insert the solution tube following the solution tube insertion instructions in this manual.
4. Connect the chemical feed to the inlet of the quill.

## AFTER INSTALLING / PRIOR TO OPERATING

1. Inspect the restraint system to ensure that it is properly in place and ready for operation. Check to verify that:
  - a. Connector bolts are properly secured to the chain plates with the supplied locknuts.
  - b. Limit chains are attached to the threaded connectors and the threaded connectors are attached to the chain plates with the jaws closed.
  - c. Lower chain plate is properly secured to the packing nut using the four restraint screws.
2. Prior to exposing solution tube to the process pressure make sure there is a means of isolation in place to prevent process pressure from coming back up through the solution tube.

# OPERATION

## PRECAUTIONS

- Process pressure should be reduced as much as possible prior to inserting or retracting the solution tube.
- Inspect restraint hardware to ensure it is in proper condition.
- Do not stand directly in line with the quill when operating.
- Take all necessary precautions to protect against possible chemical exposure when working with the quill.
- Do not use a wrench to tighten the packing nut. Hand tighten only.

## INSERTING THE SOLUTION TUBE

1. Inspect the restraint hardware to ensure that it is suitable for use.
2. Insert the solution tube into the valve assembly until the tip contacts the ball of the closed main connection valve.
3. Connect the limit chains to the threaded connectors. For each chain, one end should attach to a threaded connector on the lower chain plate and the other end should attach to a threaded connector on the upper chain plate. Close the jaws of the threaded connectors. At this point, the chains should be extended with no kinks and minimal slack.
4. Hand tighten the packing nut until resistance is felt.
5. Before proceeding, make sure there is a point of isolation in place and active at the inlet of the quill.
6. Slowly open the valve. Allow the limit chains to take up the pressure. Tighten the packing nut to seal of any leaks.
7. Once the valve is fully open, slide the solution tube through the valve assembly until the threaded ends of the connector bolts pass through the holes of the upper chain plate. Use the lock nuts and washers to lock off the restraint system.
8. Connect the chemical feed to the quill.

## RETRACTING THE SOLUTION TUBE

1. Shutdown and isolate the chemical feed from the quill. Detach feed piping as needed to ensure the quill can retract unobstructed.
2. Maintain a firm grasp on the upper chain plate of the solution tube and remove the upper locknuts.
3. Slowly back out the solution tube until the limit chains are fully extended.
4. Isolate from the process pressure by closing the isolation valve.
5. Slowly back off the packing nut to bleed off residual pressure.
6. With the isolation valve closed and the residual pressure bled off, undo the limit chains from the threaded connectors on the upper chain plate.
7. Finish by sliding the quill completely out of the valve assembly.

# MAINTENANCE

## VISUAL INSPECTION

Periodic visual inspections should be done to examine the overall integrity of the quill and to verify that no leaks (chemical or process side) have developed.

## SOLUTION TUBE MAINTENANCE

Solution tubes may clog due to deposit formation. The rate and severity will depend on the chemistry of the application. After the quill is put into operation it should be periodically retracted to determine the rate at which the deposit formation is occurring. Maintenance cycles can then be based on observations.

Deposits can typically be removed by soaking the tube in warm water and then brushing the deposits off. In other cases a weak acid solution may be utilized.

## REPLACEMENT PARTS

The following sub-assemblies and components are available as spare parts:

- Solution Tube Assembly
- Main Connection Assembly
- Replacement Check Valves

## NEED ASSISTANCE?

### CUSTOMER SERVICE

800-957-2383

M-F (7am - 4pm Pacific)

### INSTRUCTIONAL VIDEOS

<https://saftflo.com/videos>