

EB-168

Heavy Service Retractable Injection Quill 3/4" Valve x 3/8" Tube with Check Valve



SPECIFICATIONS

SAFETY RATING	250 PSI
CHECK VALVE	INTEGRATED SPRING LOADED BALL CHECK VALVE
SAF-T-SEAL TIP	OPTIONAL
QUICK DISCONNECT	N/A
VALVE/PROCESS CONNECTION SIZE	3/4"
INLET CONNECTION SIZE	1/2"
SOLUTION TUBE SIZE	3/8"
SOLUTION TUBE ID (W/SAF-T-SEAL)	0.423"
SOLUTION TUBE ID (W/O SAF-T-SEAL)	0.493"
SOLUTION TUBE OD	0.675"
(A) OPERATING LENGTH	11.75"
(B) VALVE/GLAND LENGTH	7.5"
EXTRACTION LENGTH	19.25" + INSERTION LENGTH

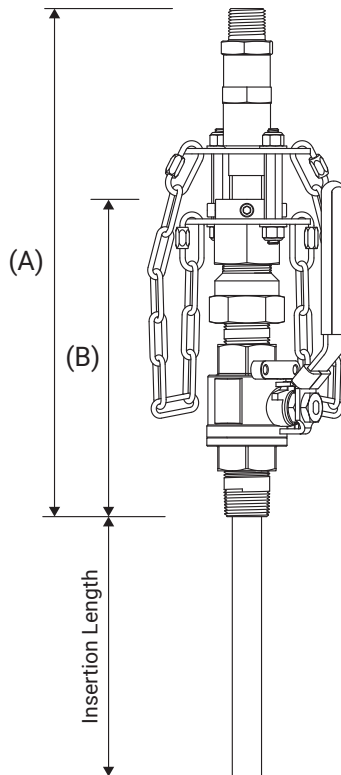

ORDERING INFORMATION

SERIES	VALVE MATERIAL	SOLUTION TUBE MATERIAL	INSERTION LENGTH	TIP CONFIGURATION	CHECK VALVE SEAL
EB-168	-	-	-	-	-
	S = Stainless Steel	H = Alloy C276 S = 316SS A = Alloy 20 T = Titanium Gr.2	2 = 2" 4 = 4" 6 = 6" 8 = 8" 10 = 10" 12 = 12" 18 = 18" 24 = 24"	0 = Standard B = 45° Bevel CV = SAF-T-Seal, FKM CE = SAF-T-Seal, EPDM	V = FKM E = EPDM K = KALREZ 6375

TECH NOTES

1. Check valve spring cracking pressure is 10 PSI.
2. SAF-T-Seal tip not available with Titanium solution tube material.

